

vintola

studio

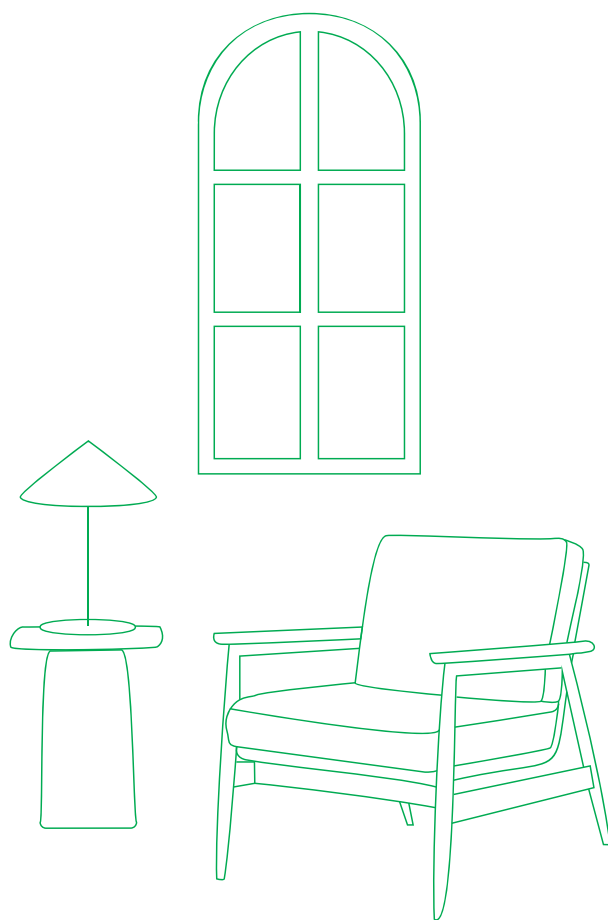

BUTTERFLY CHAIR

designed by Prof. Rajmund Halas



Chair designed by Prof. Rajmund Halas. Made of beechwood. Very beautiful original shape in butterfly type. Chair is after a complete upholstery renovation; the woodwork has been refreshed. Chairs were produced in former furniture factory in Goleniów in the 1960s.

Price: 700 €

Height: 32.29 in (82 cm)

Width: 17.72 in (45 cm)

Depth: 15.75 in (40 cm)

Seat Height: 17.72 in (45 cm)

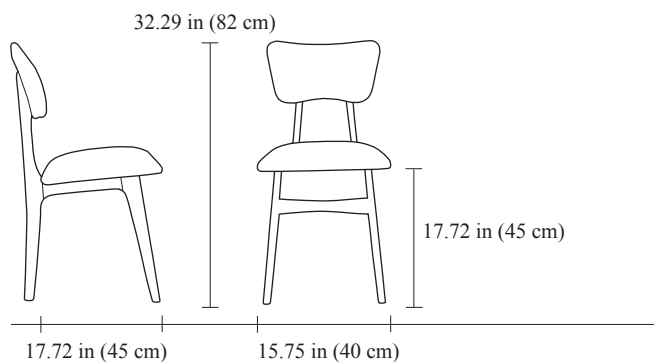

HEART CHAIR

designed by Helena and Jerzy Kurmanowicz



Chair type A5828. Colloquially called „heart”. The furniture was designed by Helena and Jerzy Kurmanowicz. Chair was produced in Radomsko Woodworking Factory and we thoroughly renovated them. First Heart Chair was produced in 1960s.

Price: 700 €

Height: 31.5 in (80 cm)
Width: 15.75 in (40 cm)
Depth: 15.75 in (40 cm)
Seat Height: 17.72 in (45 cm)

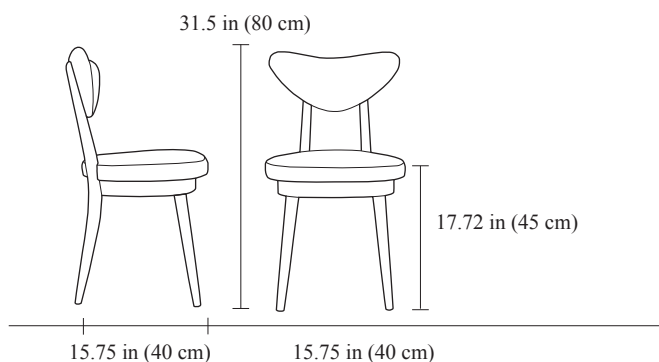

BOOMERANG CHAIR

type 299



The “Bumerang Chair” is a characteristic piece of furniture from the Polish People’s Republic (PRL) era. It's name comes from the distinctive shape of the backrest, resembling a boomerang. The chair was often made from wood or wood-like materials, featuring simple and minimalist lines, and it was commonly painted in walnut or brown colors. This iconic chair serves as an example of design from that period.

Price: 600 €

Height: 29.93 in (76 cm)

Width: 18.9 in (48 cm)

Depth: 16.54 in (42 cm)

Seat Height: 17.72 in (45 cm)

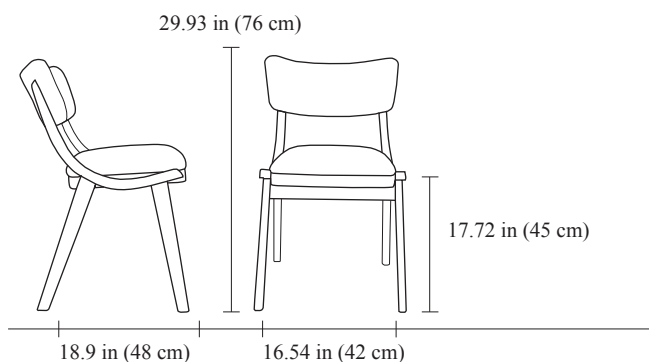

MUSHROOM CHAIR

designed by Juliusz Kedziorek



Beautiful chair type 200/128, designed by Juliusz Kedziorek and manufactured by Goscieninska Furniture Factory in Poland. A very characteristic form, one of the most interesting Polish projects. They are absolutely comfortable.

Price: 600 €

Height: 29.53 in (75 cm)

Width: 18.9 in (48 cm)

Depth: 14.97 in (38 cm)

Seat Height: 16.93 in (43 cm)

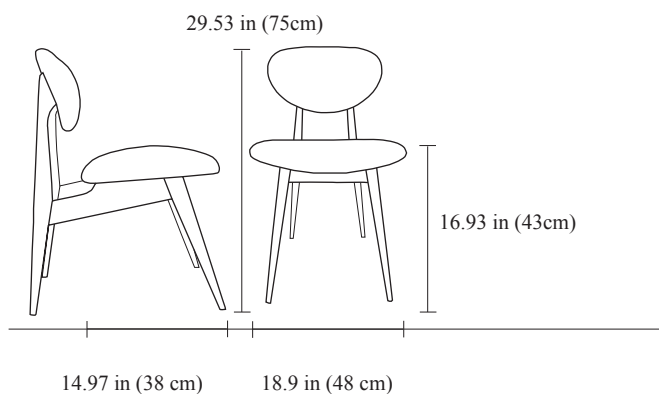

ATLANTIS ARMCHAIR

from the 1960s



Atlantis armchair from the 1960s, produced in the Silesian furniture factory in Swiebodzin/Poland at the moment they are unique. Due to their dimensions, they perfectly blend in even in small apartments providing comfort and beautiful decoration.

Price: 3000 €

Height: 31.5 in (80 cm)

Width: 33.86 in (86 cm)

Depth: 35.44 in (90 cm)

Seat Height: 15.75 in (40 cm)

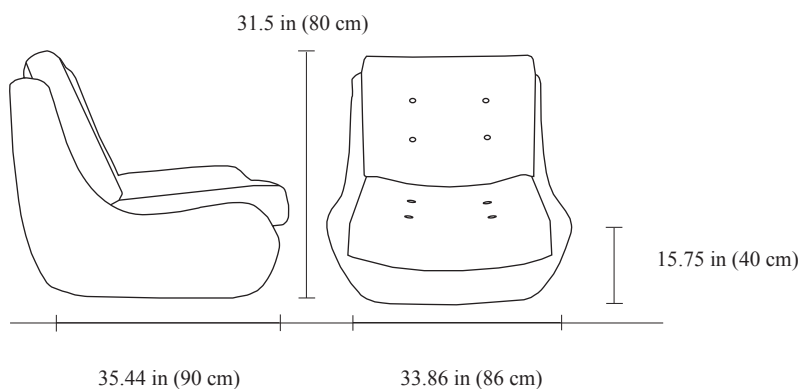

366 ARMCHAIR

designed by Jozef Chierowski



The 366 armchair is an icon of the Polish design of the PRL period. The famous armchair was designed in 1962 by the Polish interior designer and furniture designer Jozef Marian Chierowski. Produced in the Lower Silesian Furniture Factory in Swiebodzice. The chair has a simple, modernist form. It consists of an upholstered seat combined with a wooden backrest. The organic shape is typical for the 1960s style.

Price: 1800 €

Height: 27.56 in (70 cm)

Width: 24.41 in (62 cm)

Depth: 23.63 in (60 cm)

Seat Height: 15.75 in (40 cm)

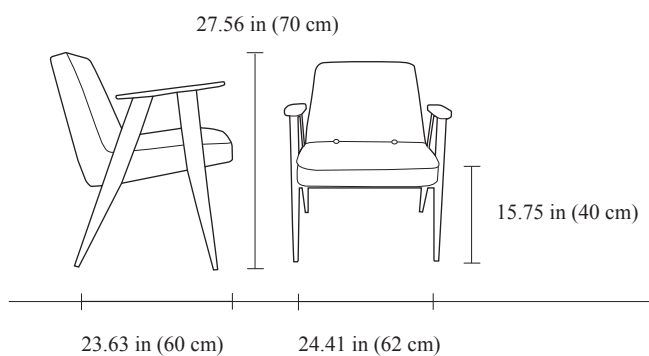

B-3300 ARMCHAIR



Radomsko B-3300 Armchair. They are super-comfortable armchairs made in the 1960s. The armchairs are made of bentwood. Very unique, comfortable and beautiful. Perfect for Minimalist interiors. The armchairs are after carpentry and upholstery renovation. The fabric used is an italian Dedar Jacquard.

Price: 1800 €

Height: 29.93 in (76 cm)

Width: 22.84 in (58 cm)

Depth: 20.48 in (52 cm)

Seat Height: 17.72 in (45 cm)

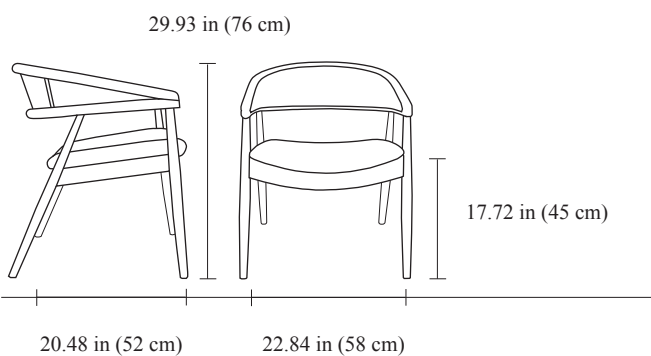

BACZYK ARMCHAIR

designed by Zenon Baczyk



The B-7522 armchair was designed in the 1960s by Zenon Baczyk, it was produced by Swarzedz furniture factories in Poland. This is an original vintage armchair after renovation, they are not new! Furnitures are kept in perfect condition, after full upholstery and wood renovation.

Price: 2400 €

Height: 27.56 in (70 cm)

Width: 19.69 in (50 cm)

Depth: 19.69 in (50 cm)

Seat Height: 15.75 in (40 cm)

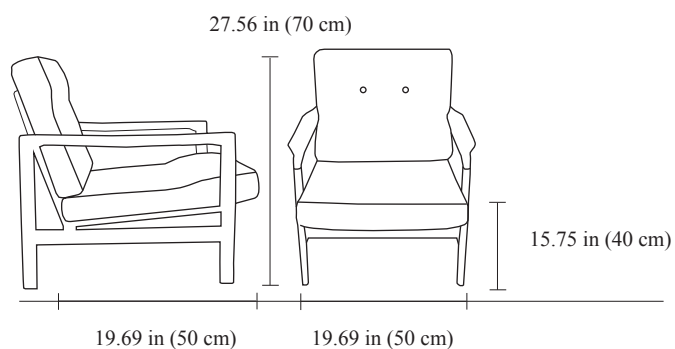

ZET ARMCHAIR



Armchair manufactured at the Bydgoszcz Renewal Cooperative in the 1970s. The armchair are after a comprehensive renovation of carpentry and upholstery. Unique and original vintage item.

Price: 2700 €

Height: 30.32 in (77 cm)

Width: 25.6 in (65 cm)

Depth: 20.87 in (53 cm)

Seat Height: 15.75 in (40 cm)

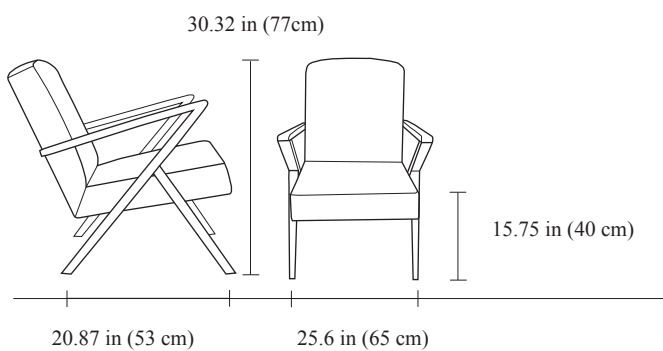

GFM 64 ARMCHAIR

designed by Edmund Homa



The armchair was made in the 1960s in the Gosiecinska Furniture Factory from solid beechwood. The GFM type armchair is regarded one of the best polish armchair design from the previous century.

Price: 1400 €

Height: 30.32 in (77 cm)

Width: 21.66 in (55 cm)

Depth: 19.69 in (50 cm)

Seat Height: 14.57 in (37 cm)

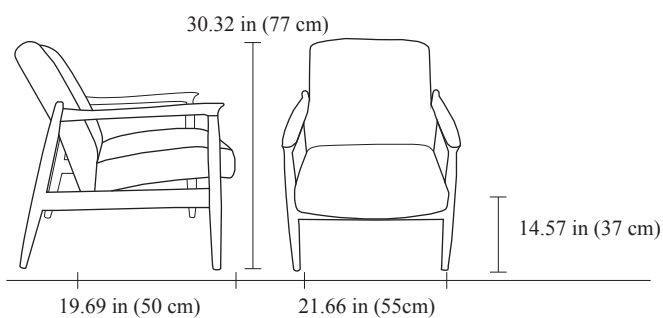

SHELL CHAIR

type 1020



Beautiful chair type 1020 colloquially called "shell" produced by the Slupsk centre of furniture industry in the 1960s in Poland.

Price: 700 €

Height: 31.5 in (80 cm)

Width: 20.87 in (53 cm)

Depth: 17.72 in (45 cm)

Seat Height: 17.72 in (45 cm)

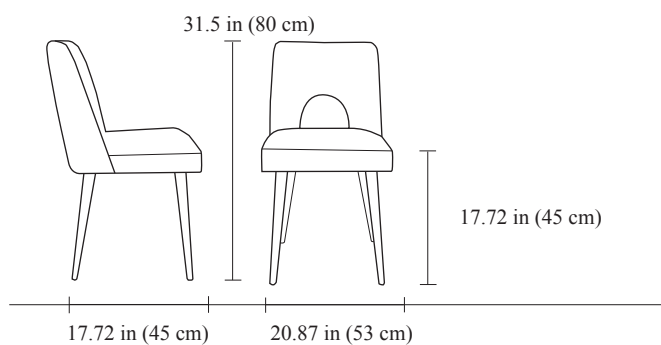

GFM 87 ARMCHAIR

designed by Juliusz Kedziorek



The GFM armchair is an icon of the Polish design of the PRL period. The famous armchair was designed in 1962 by the Polish interior designer and furniture designer Juliusz Kedziorek. Produced in the Lower Silesian Furniture Factory in Swiebodzice. This model has a simple, modernist form. It consists of an upholstered seat combined with a wooden backrest. The organic shape is typical for the 1960s style.

Price: 1600 €

Height: 27.56 in (70 cm)

Width: 24.41 in (62 cm)

Depth: 23.63 in (60 cm)

Seat Height: 15.75 in (40 cm)

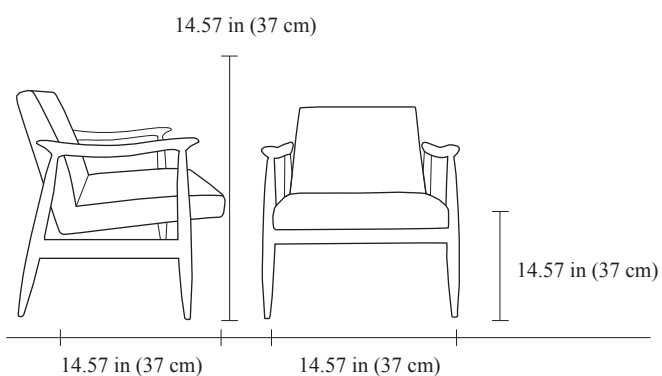

VINTOLA DINNER

designed by Vintola Studio



Springy, very comfortable and stabile club seats. They are contemporary chairs inspired of 1960s style. They can be used as armchairs and dining chairs. Chair was designed by Vintola Studio, a Polish brand created by Ola Szewczul, designer of vintage interior architecture and photographer.

Price: 900 €

Height: 32.29 in (82 cm)

Width: 21.66 in (55 cm)

Depth: 19.69 in (50 cm)

Seat Height: 18.51 in (47 cm)

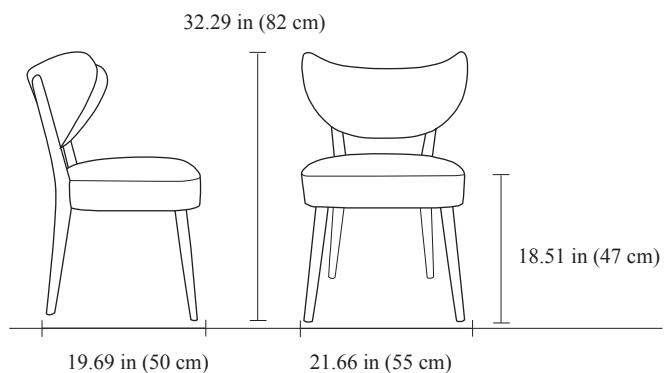

VINTOLA LOUNGE

designed by Vintola Studio



Springy, very comfortable and stabile club seats. They are contemporary chairs inspired by 1960s style. They can be used as armchairs and dining chairs. Chair was designed by Vintola Studio, a Polish brand created by Ola Szewczul, designer of vintage interior architecture and photographer.

Price: 800 €

Height: 29.53 in (75 cm)

Width: 21.66 in (55cm)

Depth: 19.69 in (50 cm)

Seat Height: 16.54 in (42 cm)

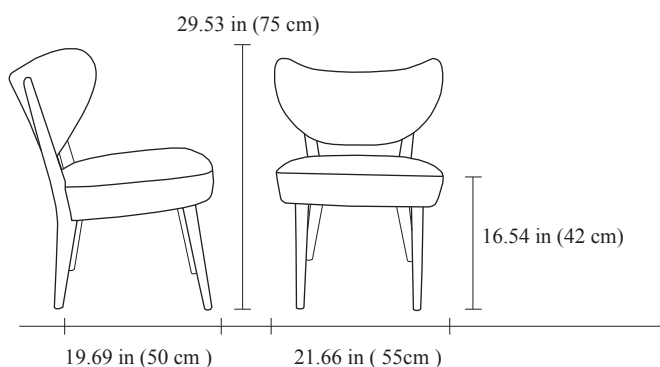

VINTOLA STOOL SMALL

designed by Vintola Studio



Comfortable and stabile triangle stool. They are contemporary stools inspired of 1960s style. Stool was designed by Vintola Studio, a Polish brand created by Ola Szewczul, designer of vintage interior architecture and photographer.

Price: 200 €

Height: 17.72 in (45 cm)

Width: 13 in (33 cm)

Depth: 13 in (33 cm)

Seat Height: 17.72 in (45 cm)

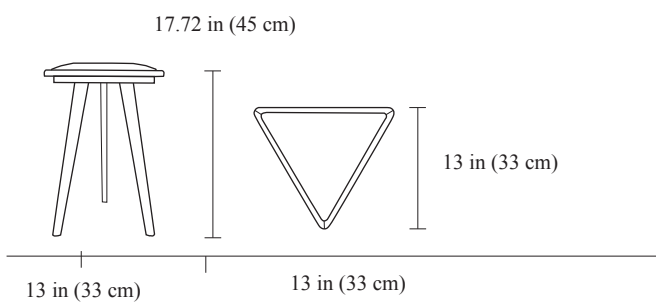

VINTOLA STOOL BIG

designed by Vintola Studio



Comfortable and stabile triangle stool. They are contemporary stools inspired by 1960s style. Stool was designed by Vintola Studio, a Polish brand created by Ola Szewczul, designer of vintage interior architecture and photographer.

Price: 300 €

Height: 23.63 in (60 cm)

Width: 13.78 in (35 cm)

Depth: 13.78 in (35 cm)

Seat Height: 23.63 in (60 cm)

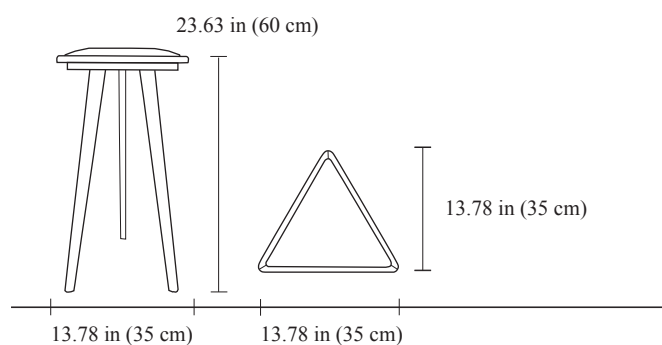

VINTOLA POUF

designed by Vintola Studio



Contemporary Pouf inspired by 1960s style. The pouf consist of an upholstered part, a seat and box under the seat, characteristic of the 1960s style. Shape was designed by Vintola Studio, a Polish brand created by Ola Szewczul, designer of vintage interior architecture and photographer.

Price: 600 €

Height: 17.72 in (45 cm)

Width: 39.38 in (100 cm)

Depth: 19.69 in (50 cm)

Seat Height: 17.72 in (45 cm)

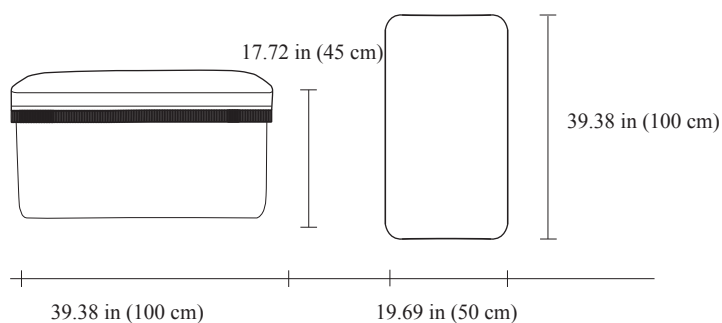

GFM STOOL

designed by Edmund Homa



The stool was made in the 1960s in the Goscięcinska Furniture Factory from solid beechwood. The GFM type stool is regarded one of the best polish design from the previous age.

Price: 300 €

Height: 15.75 in (40 cm)

Width: 19.69 in (50 cm)

Depth: 13.78 in (35 cm)

Seat Height: 15.75 in (40 cm)

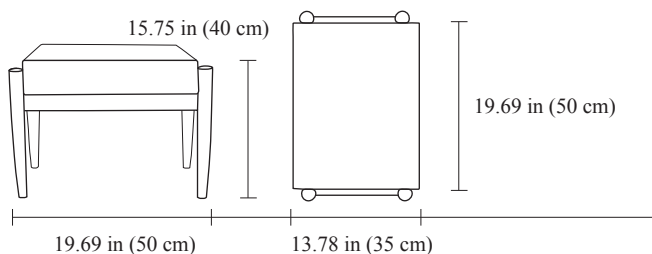

Contact us

Email Address: info@vintolastudio.com

Website: www.vintolastudio.com

Phone Number: +48 696 433 240

If you wish to order multiple items from our collection please contact us in order to receive a special offer.

Address:

Wólczyńska 65/134

01-931 Warsaw

Poland